

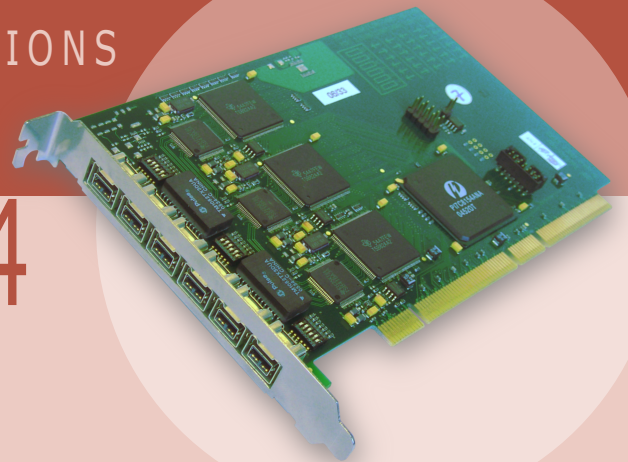

INTERFACE SOLUTIONS
PCI-CARD
MIL1394



Description

DapTechnology offers two kinds of MIL1394 **3-channel OHCI Adapters**, i.e. a PCI version and a PMC version. They address the growing need for multi-channel and transformer-coupled bus interface solutions, primarily in mission critical aerospace and defense applications requiring longer distances according to SAE AS5643-1.

Both adapter cards, which support standard 64 bit/ 66 MHz PCI interfaces, are fully OHCI compliant and feature 3 independent IEEE1394b buses. The product accommodates off-the-shelf IEEE1394b OHCI drivers from Windows™ & Linux-based operating systems. No driver modification/installation is required. Please contact DapTechnology directly regarding support for real-time operating systems like Integrity, VxWorks, etc.

The **MIL1394 3-bus standard OHCI Adapter** use the TSB41BA3 physical layer silicon from Texas Instruments and supports data transfer rates of up to 400 Mbps in Beta mode. As a special feature, the port modes on each PHY can be programmed independently via dip switches.

Key Features

- IEEE 1394b-2002 compliant
- Supports 100b, 200b, 400b data transfer rates
- 3 independent nodes with a total of 6 IEEE1394 ports.
 - active transformer coupled
 - Beta connectors
 - Port mode programming via dip switches
- PCI 2.1 compliant
- OHCI 1.1 compliant
- Supported by Windows™7 and Windows™10
 - Driver Level
 - API Level
- Driver/API Level Support for VxWorks™ and Integrity™ planned

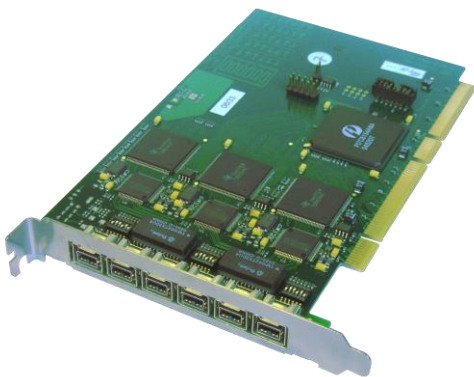

Windows™ is a registered trademark of Microsoft Corp.
 VxWorks™ is a registered trademark of Wind River Systems Inc.
 Integrity™ is a registered trademark of Green Hills Software Inc.

SPECIFICATION:

Dimensions: PCI: half length, 15 x 106 x 174 mm
Weight: PCI: 760 g
Operating Range: 0 – 70 C
Power Requirements: PCI: 12 V, 10 Watt maximum

Compliance: FCC Class A
Connections: 64bit/66MHz PCI connector, universal keyed (for 3.3V and 5V slots)
 6 IEEE1394-connectors (Beta) transformer coupled

Indicators: -
Switches: 3 dip switches for port mode programming

Package Content: MIL1394 PCI adapter
 User Guide
 3x 9-9 pin FireWire cable

Product warranty: 36 months limited warranty

Part Number: PCI341bT

Optional Configuration: -

SW Add-on modules: -

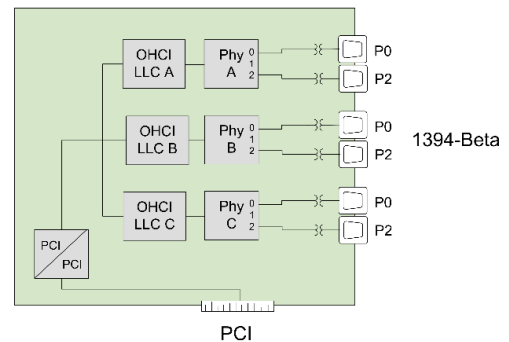

CONTACT INFORMATION:

sales@daptechnology.com

www.daptechnology.com

dap TECHNOLOGY • **dap** USA •

DapTechnology B.V.
 Beatrixstraat 4
 7573AA Oldenzaal
 The Netherlands
 Ph: +31 541 532941

DapUSA, Inc.
 780 W San Angelo Street
 Gilbert, AZ 85233
 United States of America
 Ph: +1 480 422 1551